



# H21TX

Nacelle  
à flèche  
télescopique

- Déport jusqu'à 17 m.
- Capacité maximum 360 kg.
- Dimensions panier 1.8 m x 0.8 m.
- 4 roues motrices.
- Garde au sol 34 cm.



ISO 9001  
GROUPE  
PINGUELY  
HAULOTTE



ARTICULEES



MATS



TELESCOPIQUES



CISEAUX



TRACTEES

**Haulotte**®

L'ACCES A L'ESPACE

# H21TX

## Les avantages Haulotte®

- Blocage différentiel hydraulique permettant une utilisation tout terrain
- Pneus gonflés mousse
- Longueur repliée 9.11 m facilitant le transport et la maniabilité
- Commandes entièrement proportionnelles pour l'ensemble des mouvements
- Rotation panier hydraulique 180°
- Sécurité augmentée grâce au limiteur de charge en nacelle
- Robuste, fiable et facile à entretenir

### EQUIPEMENT STANDARD

- Moteur diesel insonorisé Hatz " Silent pack "
- Contrôleur de dévers 5°
- 4 roues motrices
- Utilisation en extérieur en toute sécurité ; résiste à des vents jusqu'à 60 km/h
- Groupe électrique de descente de secours
- Commandes opérationnelles simples et faciles d'utilisation
- Batteries de démarrage 12 V - 95 Ah
- Mise en roue libre
- Compteur horaire
- Broche blocage orientation tourelle
- Anneaux de remorquage et d'éringage
- 2 anneaux dans panier pour harnais de sécurité

### OPTIONS & ACCESSOIRES

- Panier large (2.3 m x 0.8 m)
- Gyrophare
- Phare de travail
- Bruiteur de translation
- Pot catalytique
- Refroidisseur huile hydraulique
- Prise électrique dans panier
- Kit de protection environnement hostile
- Kit de protection sablage
- Module de démarrage codé



## NACELLE À FLÈCHE TÉLESCOPIQUE

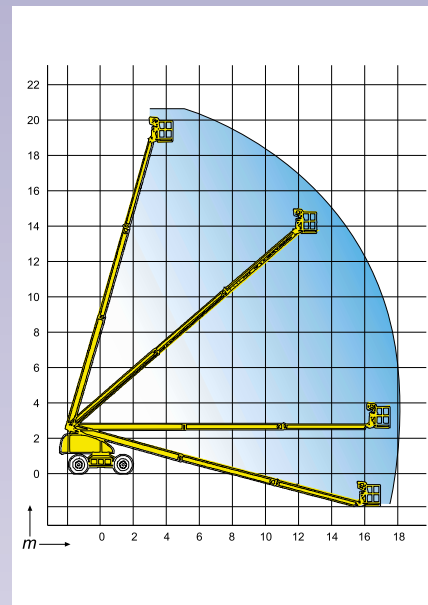
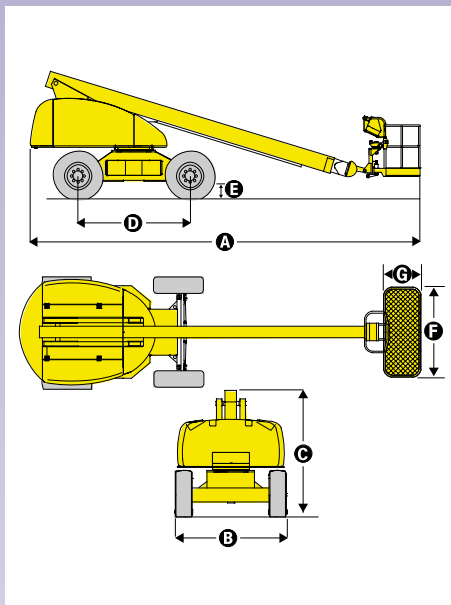

### CARACTERISTIQUES

Hauteur de travail	20.8 m
Hauteur plate-forme	18.8 m
Déport maximum	17 m
Capacité maximum	360 kg
<b>A</b> Longueur	8.91 m
<b>B</b> Largeur	2.47 m
<b>C</b> Hauteur repliée	2.84 m
<b>D</b> Empattement	2.49 m
<b>E</b> Garde au sol	34 cm
<b>F</b> x <b>G</b> Dimensions plate-forme	1.8 m x 0.8 m
Déport arrière	1.06 m
Vitesse de translation	1.5 - 5.0 km/h
Rayon de braquage extérieur	6.15 m
Rotation hydraulique tourelle continue	360°
Rotation panier hydraulique	180°
Moteur	Diesel 53 CV
Commandes	proportionnelles
Pente maximum	40%
Pneus gonflés mousse	15 R 22.5 XF
Réservoir hydraulique	150 l
Réservoir gasoil	150 l
Poids total	13.100 kg

┌ D I S T R I B U E P A R ┐

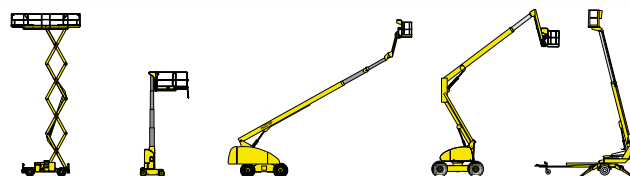

**Haulotte®**



# H21TX

Telescopic  
boom

- 55 ft 9 in (17 m) outreach.
- 793 lb (360 kg) platform capacity.
- Foam filled tyres.
- 14 in (34 cm) ground clearance.



ISO 9001  
GROUP  
PINGUELY  
HAULOTTE



ARTICULATED BOOMS



VERTICAL MASTS



TELESCOPIC BOOMS



SCISSOR LIFTS



TRAILERS

**Haulotte®**

ON THE UP

# H21TX

## TELESCOPIC BOOM

### The Haulotte® advantages

- Standard foam filled tyres.
- 4 wheel drive.
- Length : 9.11 / 29 ft 11 in
- Hydraulic differential lock for demanding rough terrain conditions.
- Work platform overload limiter increases safety.
- Large & robust slewing ring
- Simultaneous proportional controls for all movements.
- Side mounted engine for easy access & maintenance.
- Improved productivity through fast boom movement speeds.
- Robust, reliable, easy to maintain design.

### STANDARD FEATURES

- 62 ft (18.86 m) platform height
- 5° tilt alarm
- 180° hydraulic platform basket rotation
- Silent pack Hatz diesel engine
- Free wheeling device
- Electric emergency lowering system
- Safe use in winds up to 37 mph (60 km/h)
- Simple uncomplicated operational controls
- Turret slewing lock rod
- Hourmeter
- Towing hooks / lifting eyes in platform

### OPTIONS & ACCESSORIES

- Large platform (2.3 m x 0.8 m / 7 ft 6 in x 2 ft 7 in)
- Rotating beacon
- Catalytic exhaust
- Working light
- Travel alarm
- Power line to cage
- Oil cooler
- Airline to cage
- Hostile environment kit
- Sandblast protection kit
- Encoded starting device

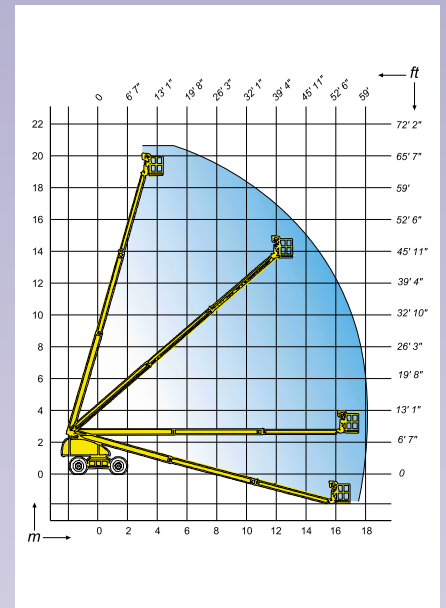
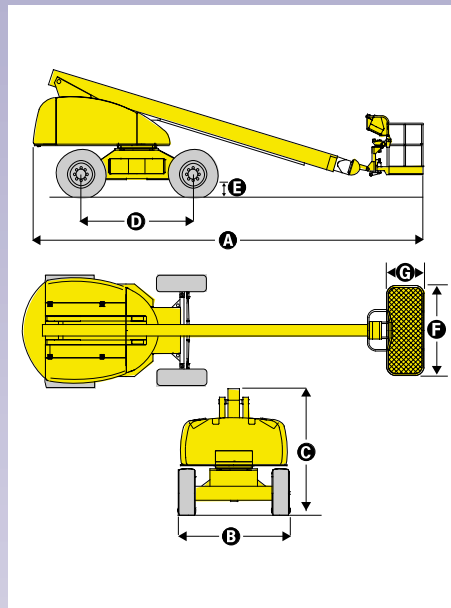

### SPECIFICATIONS

Working Height	68 ft	20.86 m
Platform Height	62 ft	18.86 m
Horizontal Reach	55 ft 9 in	17 m
Platform Capacity	793 lb	360 kg
<b>A</b> Length	29 ft 3 in	8.91 m
<b>B</b> Width	8 ft 1 in	2.47 m
<b>C</b> Stowed Height	9 ft 3 in	2.84 m
<b>D</b> Wheelbase	8 ft 2 in	2.49 m
<b>E</b> Ground clearance	13 1/2"	34 cm
<b>F</b> x <b>G</b> Platform size	71 in x 32 in	1.8 m x 0.8 m
Tailswing	42 in	1.06 m
Drive speed	0.9 - 3.1 mph	1.5 - 5.0 km/h
Outside turning radius	20 ft 2 in	6.15 m
Turntable Rotation - Continuous	360°	360°
Platform Rotation	180°	180°
Power source	Diesel 53 hp - 38 kw	
Controls	12 V proportional	
Gradeability	40%	
Tyres (Foam Filled)	15 R 22.5 XF	
Hydraulic tank	40 gallons	150 l
Fuel tank	40 gallons	150 l
Weight	28.820 lb	13.100 kg

AS1418.10

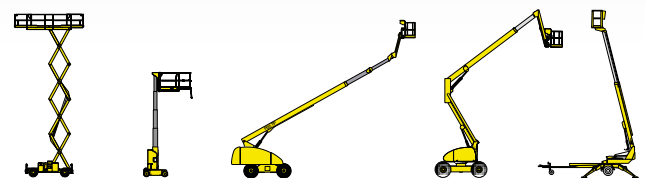

# Haulotte®