

MULTITEL



J2A65TA



- Commandes électro-hydrauliques proportionnelles avec la possibilité de réglage de la vitesse de tous les mouvements, aussi bien du sol que de la nacelle.
- Système électronique de limitation de vitesse en fonction du développement de l'élévateur.
- Amortissement automatique en approche de butée de mouvement.
- Possibilité d'effectuer tous les mouvements de façon simultanée.
- Mesure de la charge embarquée en nacelle, avec dispositif anti surcharge.
- Panier extensible hydrauliquement.
- Sortie hydraulique des éléments télescopiques du bras.
- Chemins de câbles internes au bras.
- Clapets anti-retour sur tous les mouvements.



- Proportional electro-hydraulic controls from both control posts.
- Electronic speed limiting device according to the extension of the boom.
- Electronic damping of the speed at final positions.
- Possibility of several contemporary manoeuvres.
- Load sensing device on the cage with overload device.
- Hydraulically extendible cage.
- Synchronous multi-stage telescope cylinders.
- Internal hose and cable ducts.
- Hydraulic check valves on all movements.



- Elektro-Hydraulische Proportionalsteuerung mit Geschwindigkeitsregelung für alle Funktionen, von Korb- und Bodenbedienung.
- Elektronische Geschwindigkeitsselbstbegrenzung abhängig von dem Teleskopsausfahren.
- Elektronische Geschwindigkeitsdämpfung am Ende sämtlicher Schaltungen.
- Möglichkeit mehrerer gleichzeitiger Bedienungen.
- Kontrolle der Tragfähigkeit des Arbeitskorbes mit Lastmomentbegrenzung.
- Hydraulisch verlängerbarer Arbeitskorb.
- Synchron-ausfahrende Mehrstufen Teleskop-Zylinder.
- Innenliegende Kabel- und Schlauchverlegung.
- Hydraulische Sperrventile auf jede Bewegung.



- Comando elettroidraulico proporzionale con regolazione della velocità di tutti i movimenti sia dal cestello che da terra
- Sistema elettronico di autolimitazione della velocità in funzione dell'estensione dei bracci
- Ammortizzazione elettronica della velocità a fine manovra
- Possibilità di effettuare più manovre contemporaneamente
- Lettura del carico sul cestello con dispositivo antisovraccarico
- Cestello estensibile idraulicamente
- Uscita oleodinamica degli sfilii telescopici dei bracci
- Tubi e cavi installati all'interno dei bracci
- Valvole di blocco su ogni movimento.

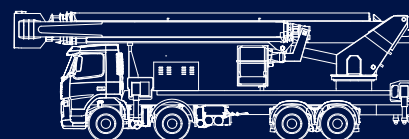
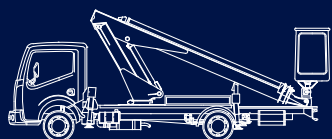



J2 365 TA

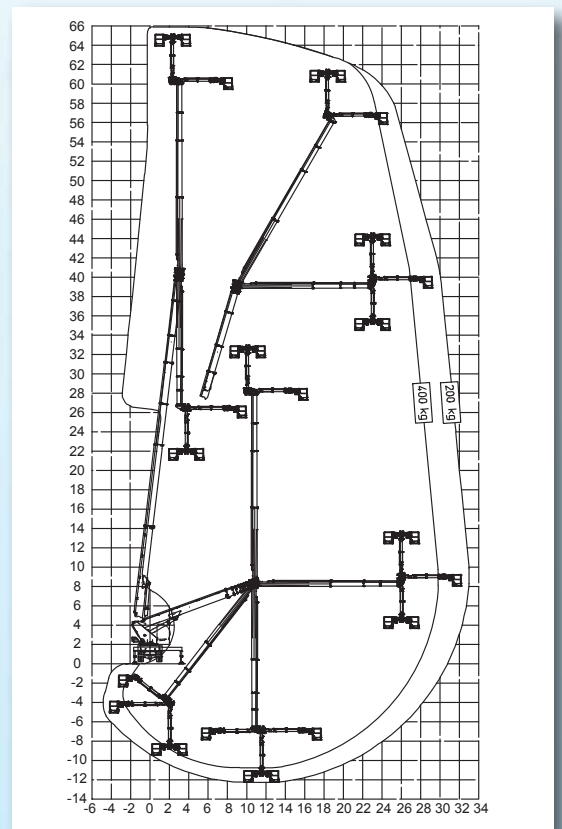
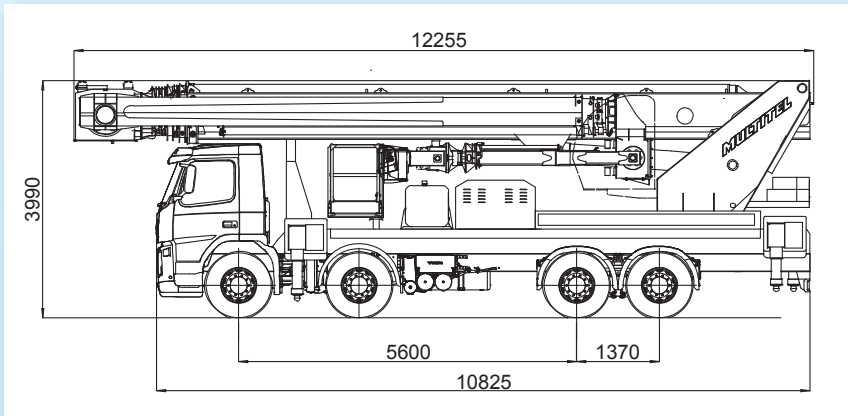

Hauteur de travail env.	Max working height	Maximale Arbeitshöhe	Altezza max di lavoro	66,00 m
Hauteur plancher nacelle env.	Maximum platform height	Maximale Plattformhöhe	Altezza piano calpestio cestello	64,00 m
Déport maxi de travail env.	Max working outreach	Maximale seitliche Reichweite	Sbraccio max di lavoro	33 m (200 kg)-29,80 m (400 kg)
Rotation de la tourelle (continus)	Turret rotation (continuous)	Schwenkbereich (endlos)	Rotazione torretta (continui)	360°
Rotation de la nacelle	Cage rotation	Hydraulische Korbdrehung	Rotazione idraulica del cestello	360°
Sortie télescopique des bras.	Boom telescopic amplitude	Teleskopaus Schub	Escursione telescopica dei bracci	37,55 m
Angle d'articulation du pendulaire	Rotation angle of the 2° boom	Drehwinkel des Gelenkauslegers	Angolo di articolazione 2° braccio	300°
Angle d'artic. de l'element terminal	Rotation angle of the final element	Drehwinkel des Endauslegers	Angolo di artic. elemento terminale	270°
Dimensions nacelle	Cage dimensions	Arbeitskorbabmessungen: LxBxH	Dimensioni del cestello	3,60 x 0,90 x 1,15 m
Charge utile en nacelle	Safe working load on cage	Tragfähigkeit	Portata cestello	200/400 kg

MULTITEL



MULTITEL PAGLIERO S.P.A.
 Strada Statale, 114
 12030 MANTA (CN) - ITALY
 Tel. +39 0175 255211
 Fax +39 0175 255255
 info@multitelgroup.com
 www.multitelgroup.com

Filiali
 Corso Piemonte, 54
 10099 S. MAURO T.S.E (TO)
 Tel. +39 011 2236792
 Fax +39 011 2236761

Via dell'Offelera, 106
 20047 BRUGHERIO (MB)
 Tel. +39 039 883393/4
 Fax +39 039 2872140

Export sales
 Jerry W. Kist
 107, rue Ten Eycken
 4850 PLOMBIERES - BELGIUM
 Tel. +32 47 755 56 67
 Fax +32 87 78 41 48
 j.kist@pagliero.com

MULTITEL INTERNATIONAL SAS
 87, rue du Morellon
 38070 ST. QUENTIN FALLAVIER - FRANCE
 Tel. +33 (0)4 74 94 63 19
 Fax +33 (0)4 74 94 46 97
 info@multitelinternational.com