

**UpRight**  
INTERNATIONAL  
**UL25/32/40**

personnel lifts  
telescopic mast

Patented Girder Lock  
telescopic mast system  
feels solid and sturdy

Ground level entry

Choice of platform heights

Small footprint allows  
set up in narrow aisles,  
tight spaces

Fast set-up increases  
productivity

EZ Loader system for  
transporting by pick-up  
truck

Tilt-back system allows  
passage through  
standard doorways

AC power

Five year  
structural warranty

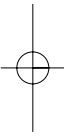
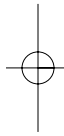

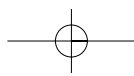

specifications	UL25	UL32	UL40
working height (A)	9.6m. (31ft.)**	11.72m. (38ft.)**	14.15m. (46ft.)**
platform height - (max.) (B)	7.6m. (25ft.)	9.72m. (32ft.)	12.15m. (40ft.)
platform height - (lowered) (C)	n/a	n/a	n/a
platform capacity	159kg. (350lbs.)	136kg. (300lbs.)	136kg. (300lbs.)
platform size	0.56m. x 0.66m. (22ins. x 26ins.)	0.56m. x 0.66m. (22ins. x 26ins.)	0.56m. x 0.66m. (22ins. x 26ins.)
stowed dimensions: width (G)	0.74m. (29ins.)	0.74m. (29ins.)	0.74m. (29ins.)
height (C)	1.98m. (78ins.)	2.53m. (99.5ins.)	2.90m. (114ins.)
length (D)	1.26m. (49.5ins.)	1.32m. (52.5ins.)	1.32m. (52.5ins.)
tilted back: height (E)	1.90m. (74.75ins.)	1.85m. (72.75ins.)	2.00m. (79ins.)
length (F)	2.59m. (102ins.)	(107ins.) 2.72m.	3.05m. (120ins.)
outrigger footprint	1.50m. x 1.43m.	2.06m. x 1.99m.	2.34m. x 2.26m.
width x length (J x H)	(59ins. x 56ins.)	(81ins. x 78ins.)	(92ins. x 89ins.)
wall / corner access	n/a	n/a	n/a
wall access - distance from			
front of platform to wall	102mm. (4ins.)	356mm. (14ins.)	508mm. (20ins.)
weights: AC	349kg. (770*lbs.)	417kg. (920lbs.)	449kg. (990lbs.)
guardrail height	1.1m. (43.5ins.)	1.1m. (43.5ins.)	1.1m. (43.5ins.)
toeboard height	152mm. (6ins.)	152mm. (6ins.)	152mm. (6ins.)
power source	AC electric motor 1 hp single phase 110/220V, 50/60Hz		
battery charger	Automatic 110V, 60Hz	Automatic 110V, 60Hz	Automatic 110V, 60Hz

\*AC with tilt back 381kg. (840 lbs.)

\*\*Metric working height is 2m above platform height. Working height in the U.S. is 6 ft. above platform height.

Specifications subject to change without notice. Photos and diagrams in this brochure are for promotional purposes only. Refer to appropriate UpRight International Operators manual for detailed instructions on the proper use and maintenance of this equipment.

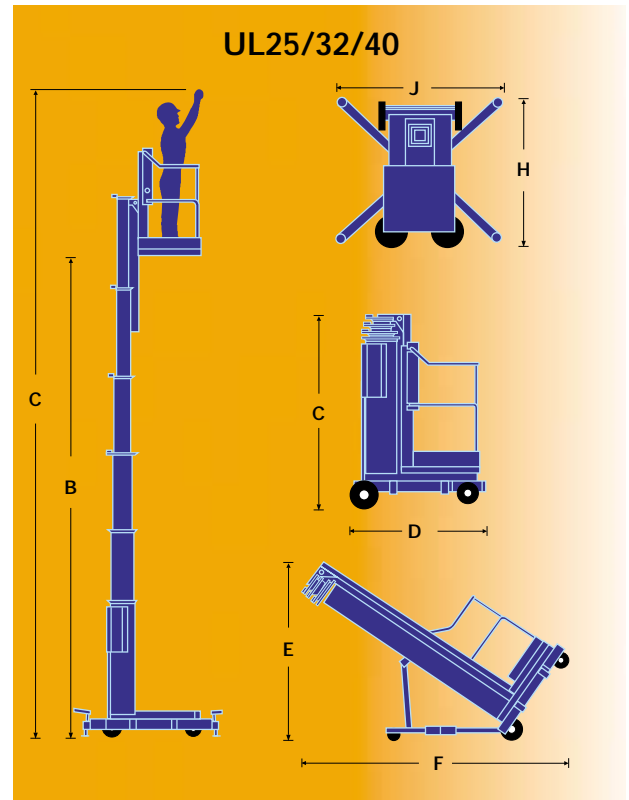

UI 25/32/40 models are fitted with the EZ loader system to assist loading onto pickup trucks.



Thanks to the tilt-back system all models will pass through standard single doorways. Large diameter rear wheels on roller bearings move easily over thresholds.

manufactured by  
**UpRight**  
INTERNATIONAL

Meets or exceeds applicable requirements of OSHA and ANSI A92.3 - 1990.  
**CE** This product is available with the CE mark confirming compliance with all relevant European Machinery Directives

## standard features

- Tiltback mechanism (UL 32/40 models only)
- Outrigger interlock indicators
- Power to platform
- 1 year parts/service
- 5 year structural warranty

## options

- Laser locator
- Power to platform
- Canvas bag for fluorescent tubes
- Tool tray
- Narrow cage
- Short cage
- Auditorium kit
- Special paint colours
- Environmental green oil



[www.uprighteuro.com](http://www.uprighteuro.com)  
[info@uprighteuro.com](mailto:info@uprighteuro.com)

IRELAND  
Tel + (353) 1 620 9300  
Fax + (353) 1 620 9301

UK  
Tel + 44 (0) 1952 685200  
Fax + 44 (0) 1952 685255

